

**17 STAIR - SOUTH FRAME**  
 1/4" = 1'-0"

**13 STAIR - NORTH FRAME**  
 1/4" = 1'-0"

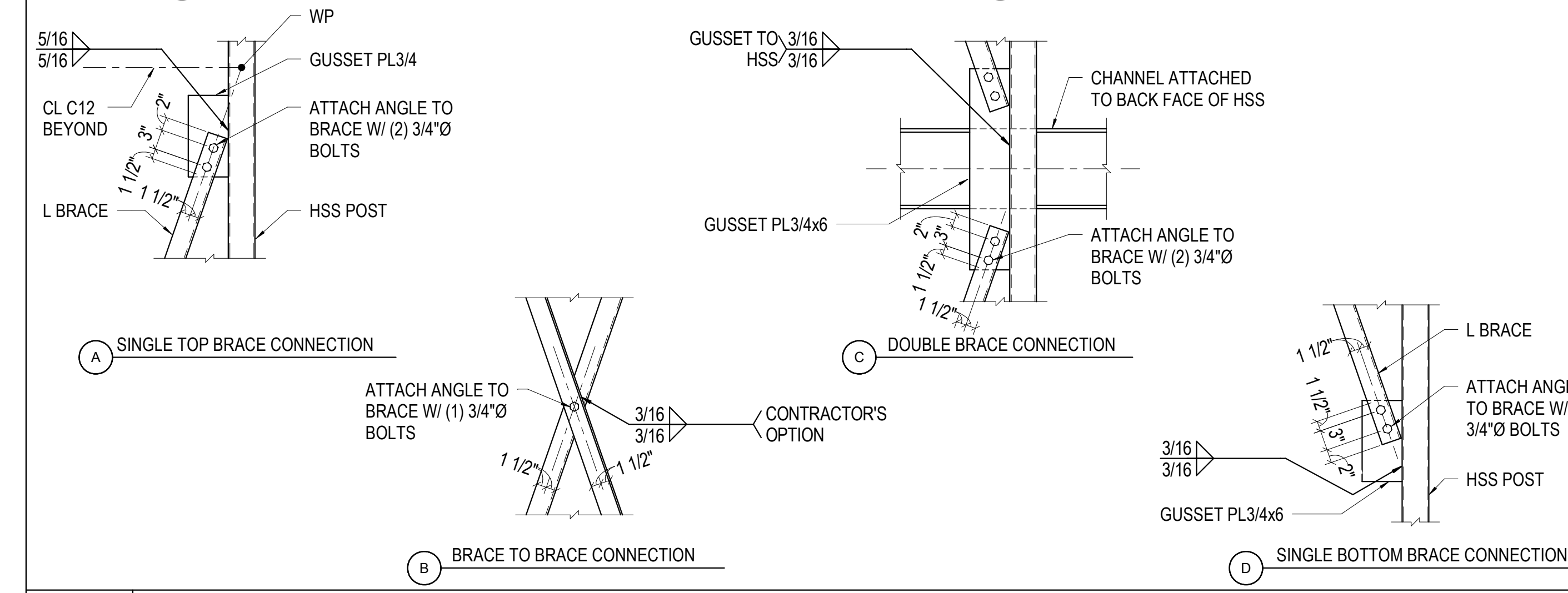

**18 NO SCALE STAIR FRAME BRACE CONNECTIONS**

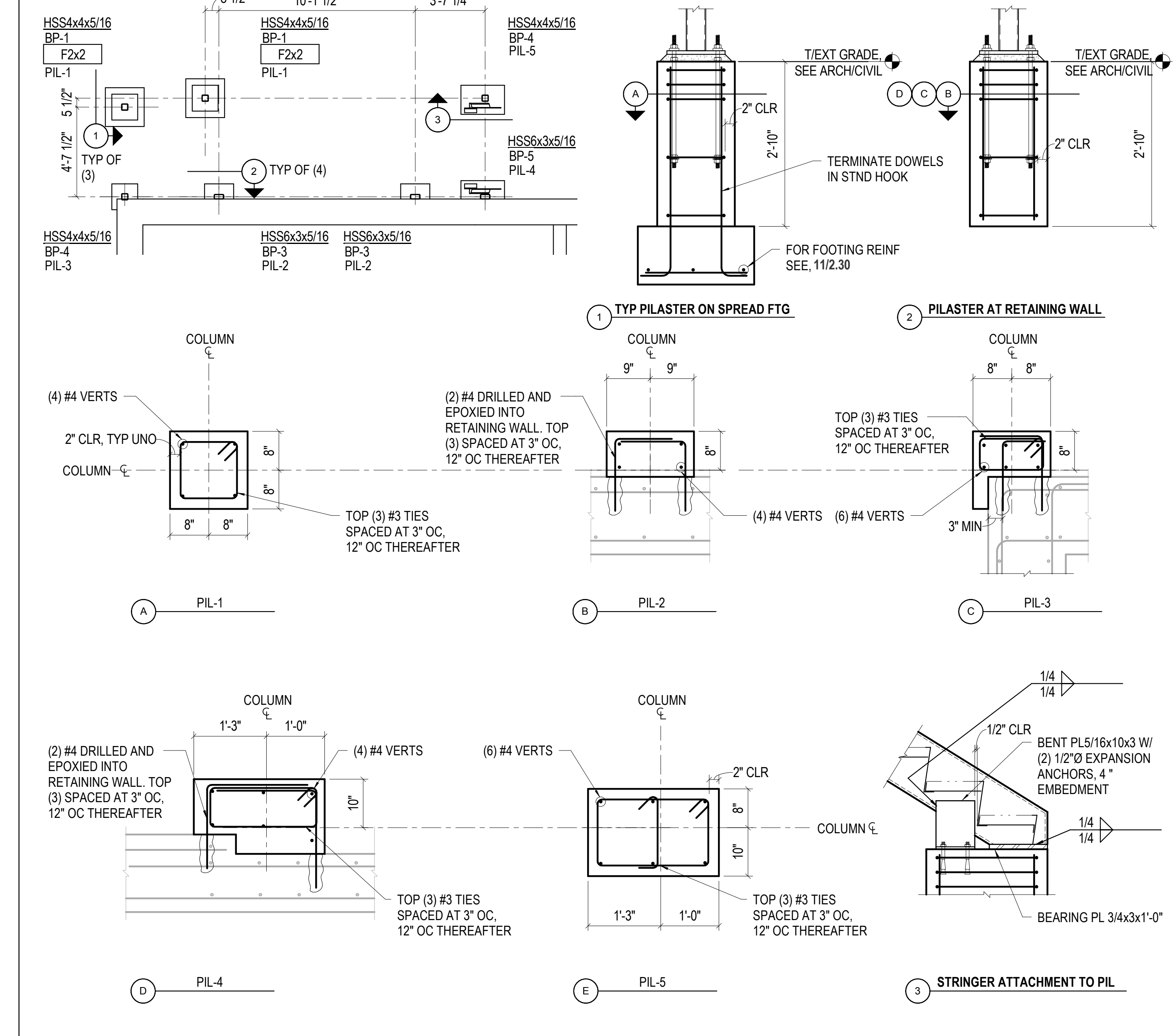

**20 NO SCALE FOUNDATION DETAILS AT STAIRS**

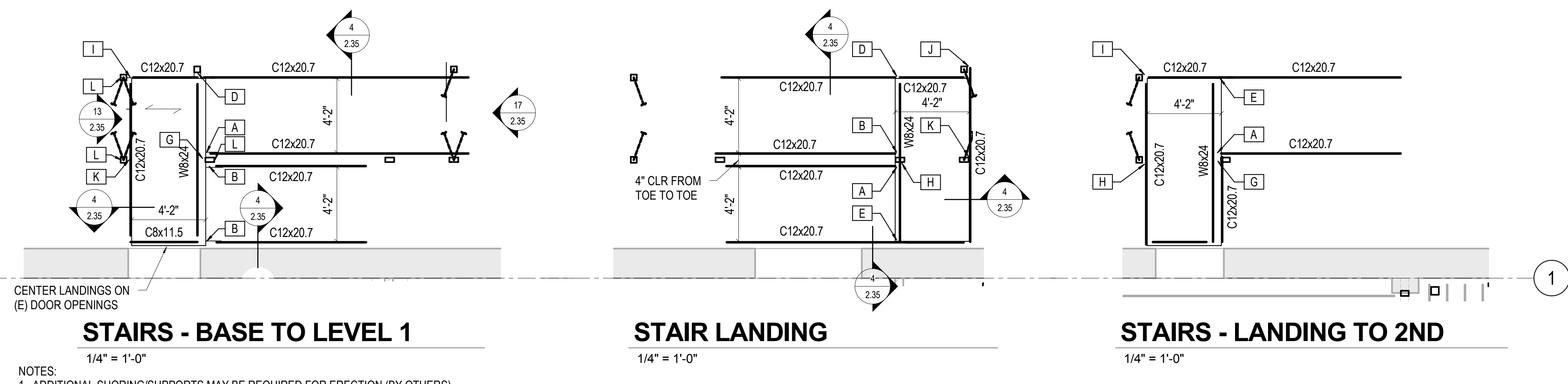

**STAIRS - BASE TO LEVEL 1**  
 1/4" = 1'-0"  
**STAIR LANDING**  
 1/4" = 1'-0"  
**STAIRS - LANDING TO 2ND**  
 1/4" = 1'-0"

**9 NO SCALE EXTERIOR FIRE ESCAPE STAIR PLANS**

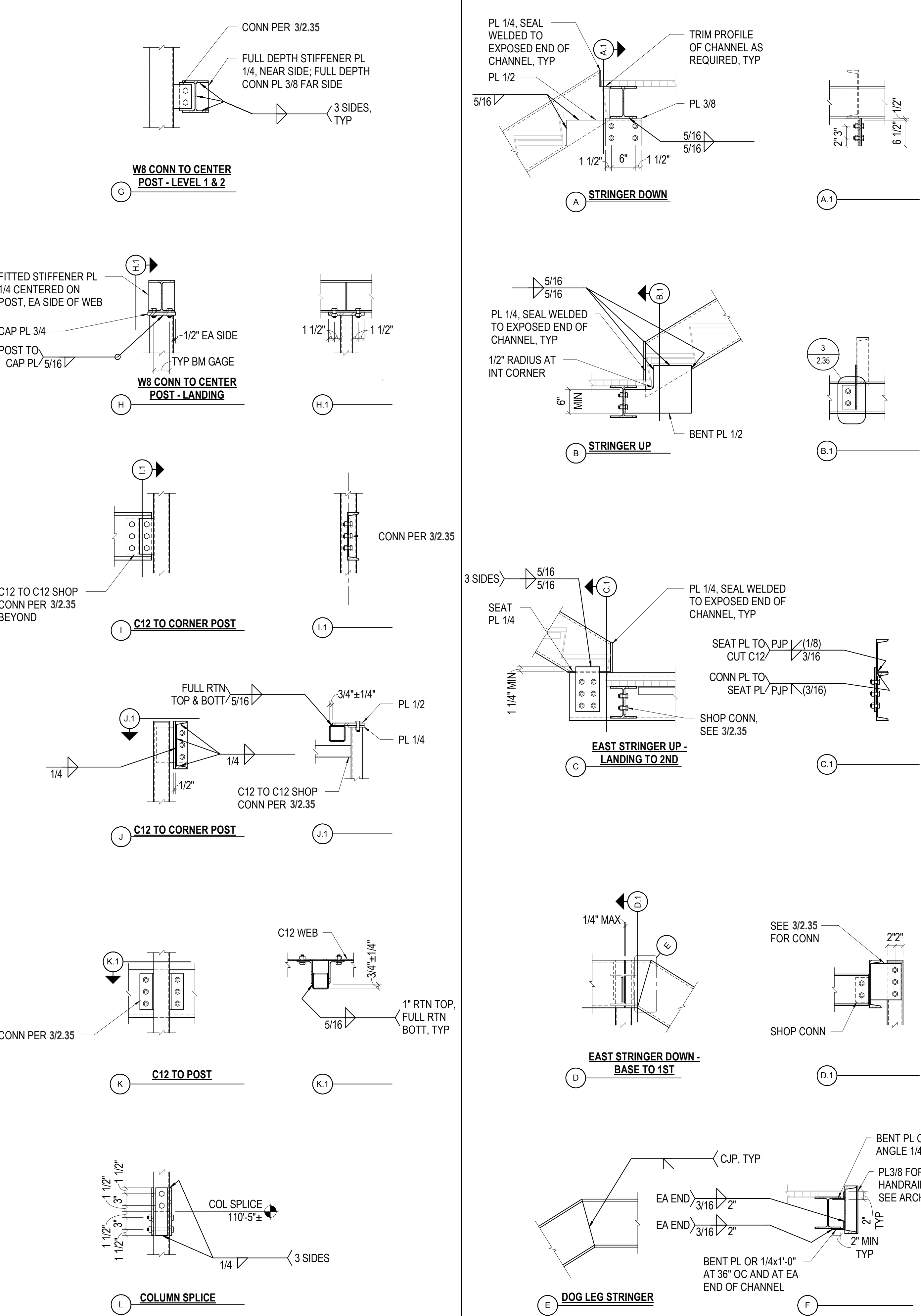

**12 NO SCALE STAIR LANDINGS TO COLUMN & COLUMN DETAILS**

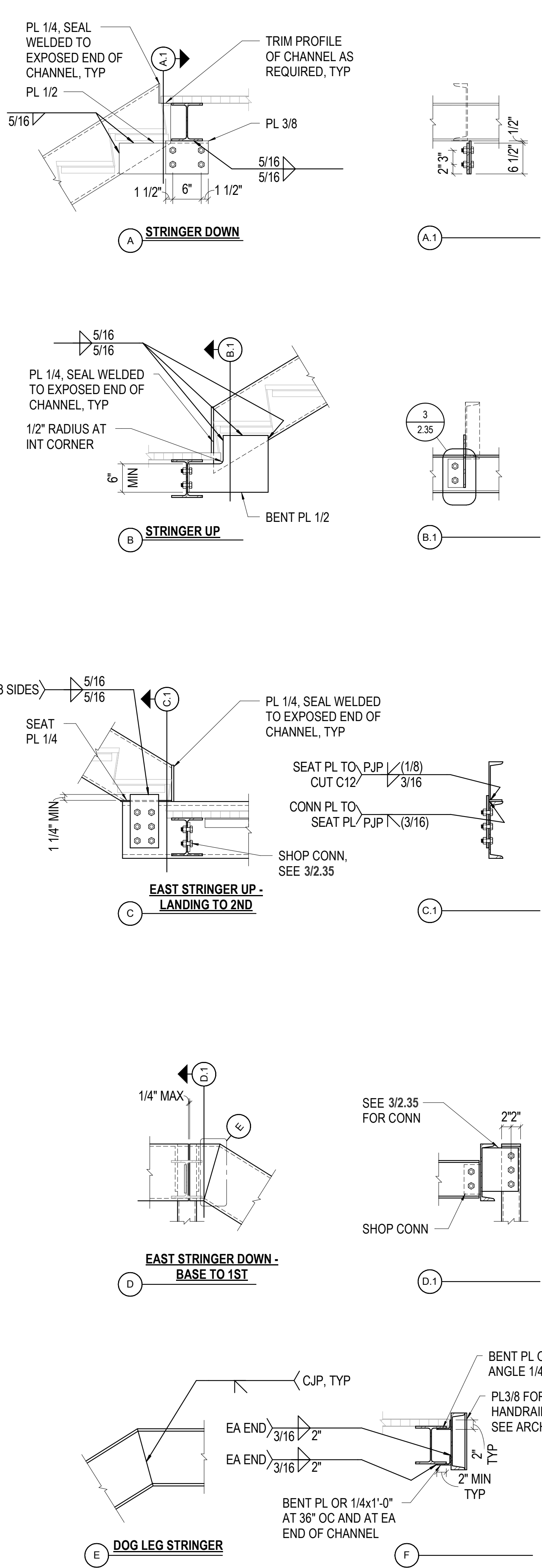

**8 NO SCALE STAIR STRINGERS TO LANDINGS**

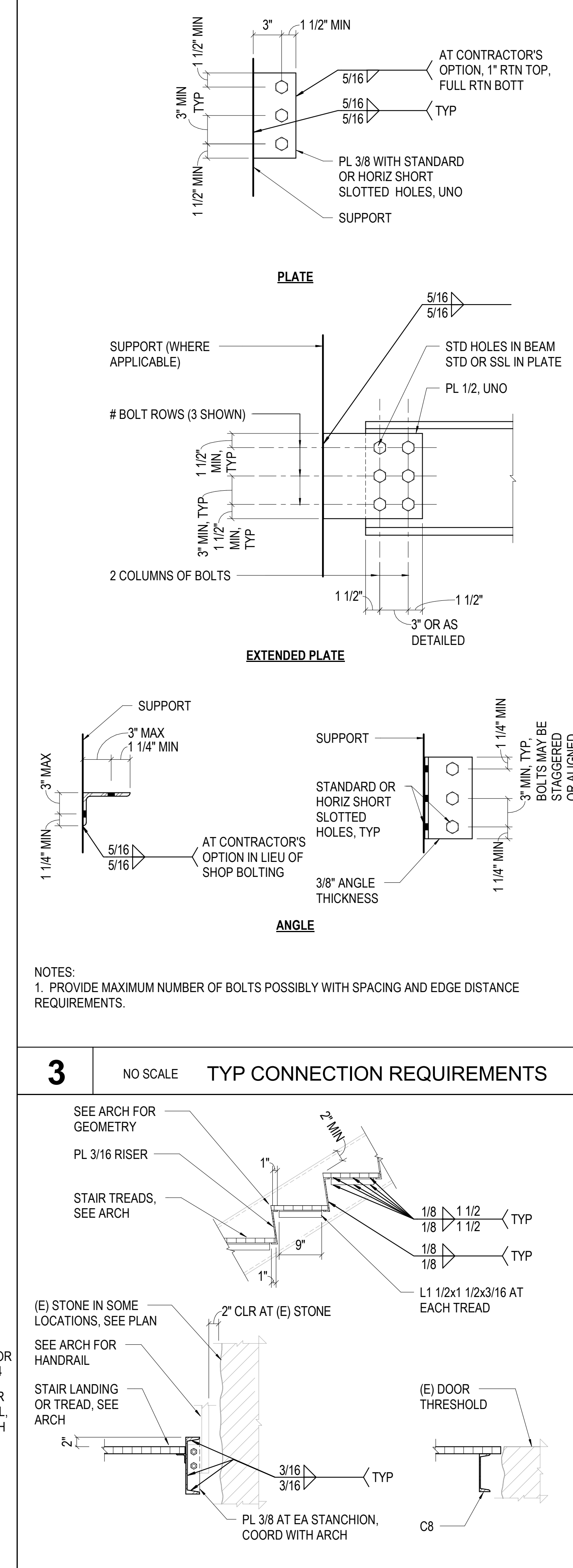

**4 NO SCALE STAIR TREADS & LANDING DETAILS**

OLD STONEY REMODEL  
 PHASE ONE  
 108 NORTH 4TH STREET  
 SUNDANCE, WYOMING 82729

Staline No 7  
 ARCHITECTS  
 4000 JARAME STREET, CHEYENNE, WYOMING 82001  
 307.657.8422

MARTIN/MARTIN  
 WYOMING  
 4000 JARAME STREET, CHEYENNE, WYOMING 82001  
 307.657.8422

PROJECT  
 16-025

DATE  
 11/20/17

DRAWN  
 NAO

DISK

SHEET  
 STAIR DETAILS

SHEET